

TIMPANI

PHILHARMONIC CLASSIC
PHILHARMONIC LIGHT

**HEAD
CHANGING**

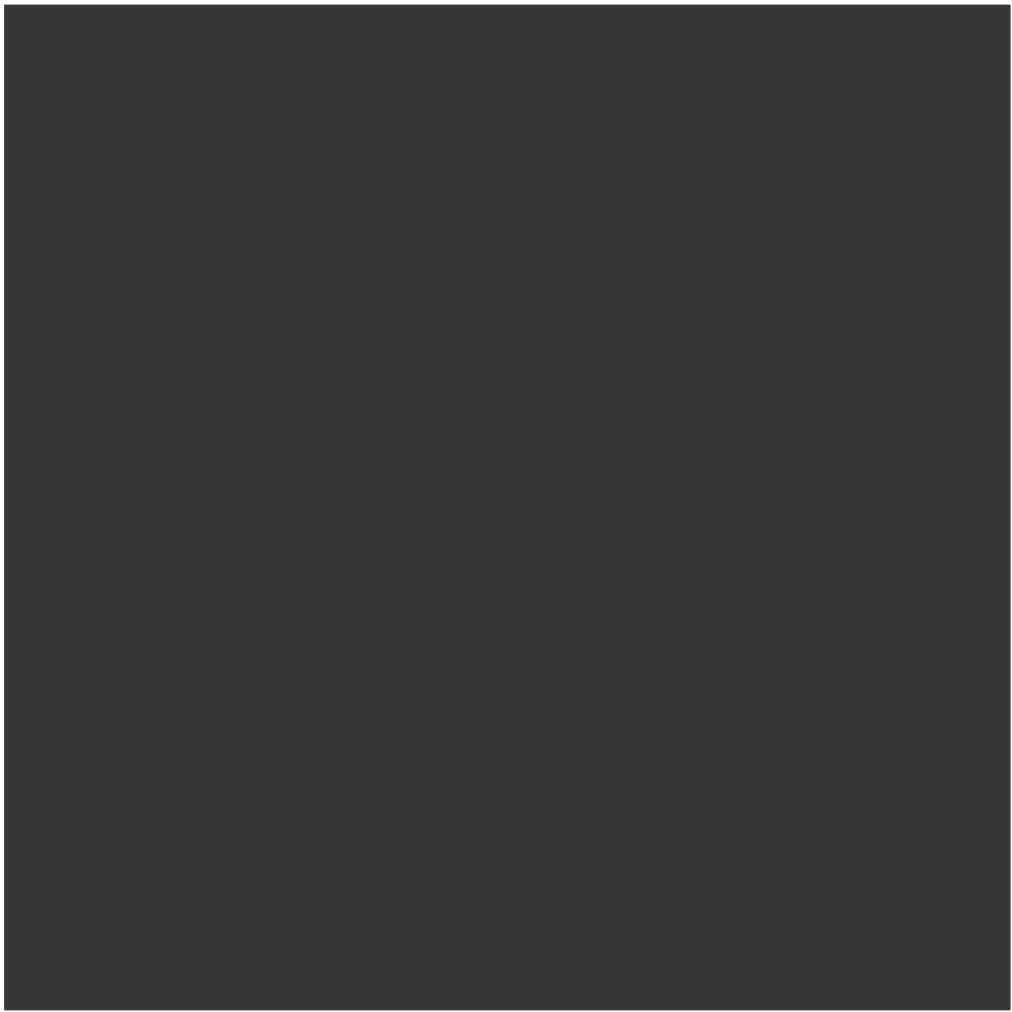



OVERVIEW

Spacers are useful for changing heads on the Philharmonic Classic models. They can also be used with the Philharmonic Light model to stabilize the star where a spring sits between the star and base.

The spacers position the star relative to the timpani base. This is necessary so that the length of the tension rods works correctly with the star, and also so that when the spacers are removed, the star can “float” unattached to the central piston. This feature reduces pressure on the frame and distributes tension between the tension rods.

The spacers hold the star and rocker arm in place when the head is removed, so it is not necessary to block the space between the rocker arm and the floor.

There are three spacer sizes: 115mm, 120mm, and 130mm:

Size	Philharmonic Classic	Philharmonic Light
20"	120mm	130mm
23"	115mm	130mm
24"	115mm	<i>not applicable</i>
25"	<i>not applicable</i>	130mm
26"	115mm	130mm
28"	<i>not applicable</i>	130mm
29"	120mm	130mm
30"	<i>not applicable</i>	<i>not applicable</i>
32"	120mm	130mm

For reference, the tension rods have the following lengths:

Size	Philharmonic Classic	Philharmonic Light
20"	585 mm	615 mm
23"	585 mm	615 mm
24"	585 mm	<i>not applicable</i>
25"	<i>not applicable</i>	615 mm
26"	585 mm	615 mm
28"	<i>not applicable</i>	650 mm
29"	615 mm	650 mm
30"	<i>not applicable</i>	650 mm
32"	615 mm	650 mm

Lengths are measured from under the head to the end of the threaded rod

PROCESS

1

Move the pedal to the position of the lowest tone.

2

Turn the fine tuner all of the way to the left.

3

Insert the metal spacers under the star on opposite sides from each other. Slightly loosen the nut on top of the star if necessary, insert the spacers as shown below, and then tighten the nut on top of the star.

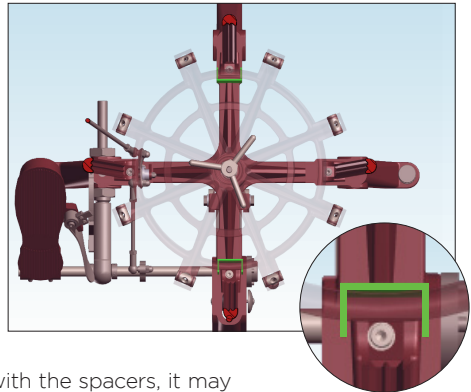
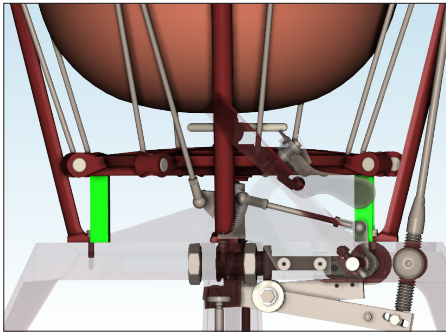

**If this is the first time that you are working with the spacers, it may not be possible to easily install them. In this case, block the space between the rocker arm and the floor, remove the tension rods and head, and then insert the spacers as shown above.

4

Turn the fine tuner to the right until the cam wheel on the rocker arm makes contact with the base, usually between 4-6 whole turns. In this position, the cam wheel should also be engaged with the rocker arm.

- If the cam wheel and rocker arm do not make contact with their corresponding parts at this point, the pedal and/or fine tuner will not correctly change the tone of the head.

Philharmonic Dresden Classic

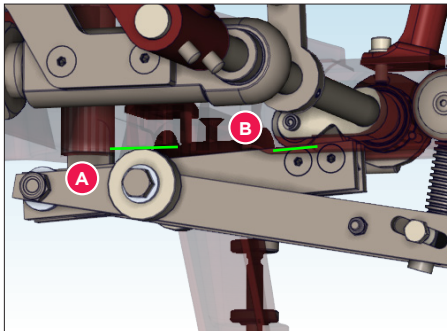

A. Rocker Arm Wheel / B. Cam Wheel

*Philharmonic Light &
Philharmonic Berlin Classic*

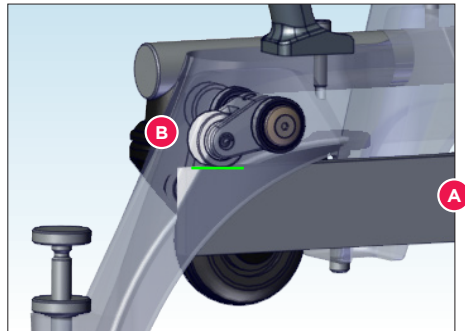

5

Loosen and remove the tension rods.

Remove the counter hoop and head.

6

If necessary, clean the kettle lip and apply new Teflon spray or replace the Teflon tape, depending on use and preference.

Replace the tension rod washers if they show signs of wear.

(Leather washer: part number PB654 / Nylon washer: part number PB418)

7

Put the new head on the kettle and the counter hoop over the head.

Put the tension rods through the ears on the counter hoop, through the head centering devices, and thread them a half a turn into the barrel nuts.

Make sure that the head is centered on the kettle. Adjust as necessary.

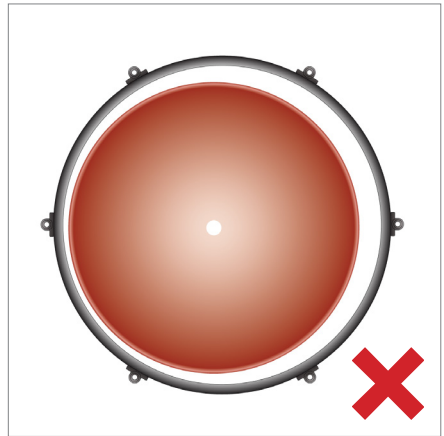
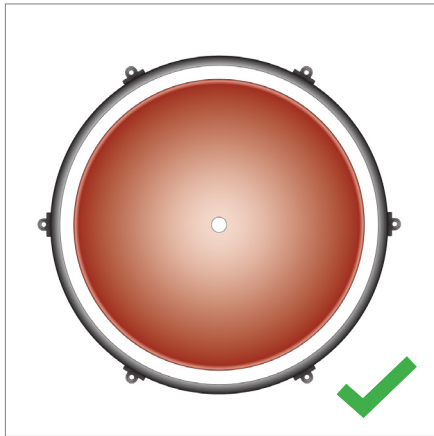

8

Turn the rods only to the point that they begin the apply tension to the head.

Then turn each tension rod 1-2 whole turns to the right, just until the head begins to show signs of tension.

- Double check that the rocker arm wheel is engaged with the base and the cam wheel is engaged with the rocker arm. If these are not, add an additional half turn to each tension rod until they are.

9

Remove the spacer from between the star and the base. Loosen the nut on top of the star, remove the spacers, and then tighten the nut on top of the star.

Double check that the head is centered.

Turn the fine tuner all the way to the left and then back to the right by 1-2 whole turns.

10

Check the fundamental tone. The fundamental tones for Philharmonic series instruments are:

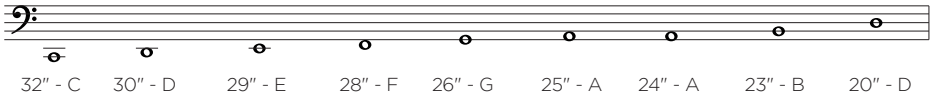

If further adjustment is needed, begin by using the fine tuner, which is most likely 1-2 whole turns. After installing a new head, the fine tuner should be at around 25-30% of its mechanical range. This will allow adjustment tighter as the head stretches after installation. If the fine tuner is already in this position, use the tension rods, which is most likely an adjustment of 1-2 whole turns to each tension rod with the tuning key.

This 25-30% position will look different on the Philharmonic Classics and Lights:

Philharmonic Dresden Classic - this model has a reverse threaded fine tuner, so as the head tension increases, the tip of the fine tuner moves higher.

Philharmonic Light and Berlin Classic—these models have a regular threaded fine tuner, so as the head tension increases, the tip of the fine tuner moves lower.

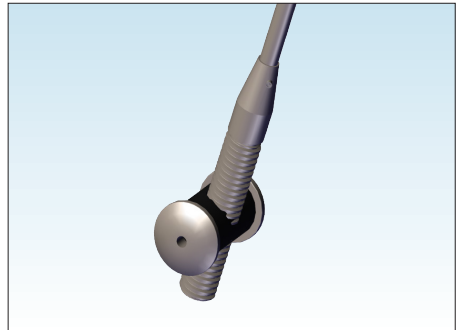
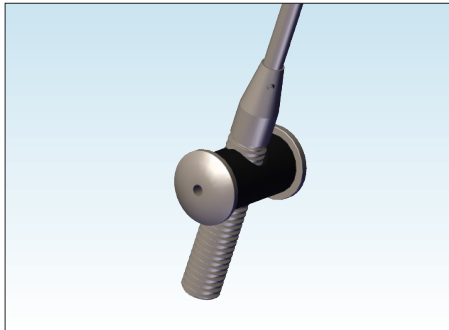

11

Move the pedal to the position of the highest tone and leave it unmoved for +/- 24 hours for the head to stretch.

After the head has stretched and settled, check the fundamental tone and adjust as necessary using either the fine tuner or the tension rods per the guidance in Step 10. Clear inconsistencies as necessary.

NOTES

1

Over time, the head will stretch and the fundamental tone will become lower. Most musicians correct this with the fine tuner on a day-to-day basis. Eventually, the fine tuner will not be near one of the positions in Step 10.

When the position of the fine tuner in the barrel nut changes dramatically, it is important to readjust how the tension is distributed between the fine tuner and the tension rods. Simply loosen the fine tuner back to the position illustrated in Step 10 and then tune the fundamental with the tension rods.

This does two things:

- It gives the fine tuner range to be either increased and decreased. A fine tuner at the top of its mechanical range can only go down, not up, which eliminates half of its purpose.
- It decreases the resistance felt in the pedal. A fine tuner at the high extreme of its mechanical range creates significant back pressure in the pedal, requiring more effort to move the pedal.

2

Calf head installation technique can be different than described above, especially in a dry environment where it will be necessary to use the fine tuner to lower the tone on a regular basis.

No matter what the adaptations to the installation technique might be, the important factor to maintain is that the rocker arm wheel is engaged with the base and the cam wheel is engaged with the rocker arm when there is no tension in the head and the spacers are installed between the star and base. If this does not occur, the pedal and fine tuner will not correctly change the tone of the head.

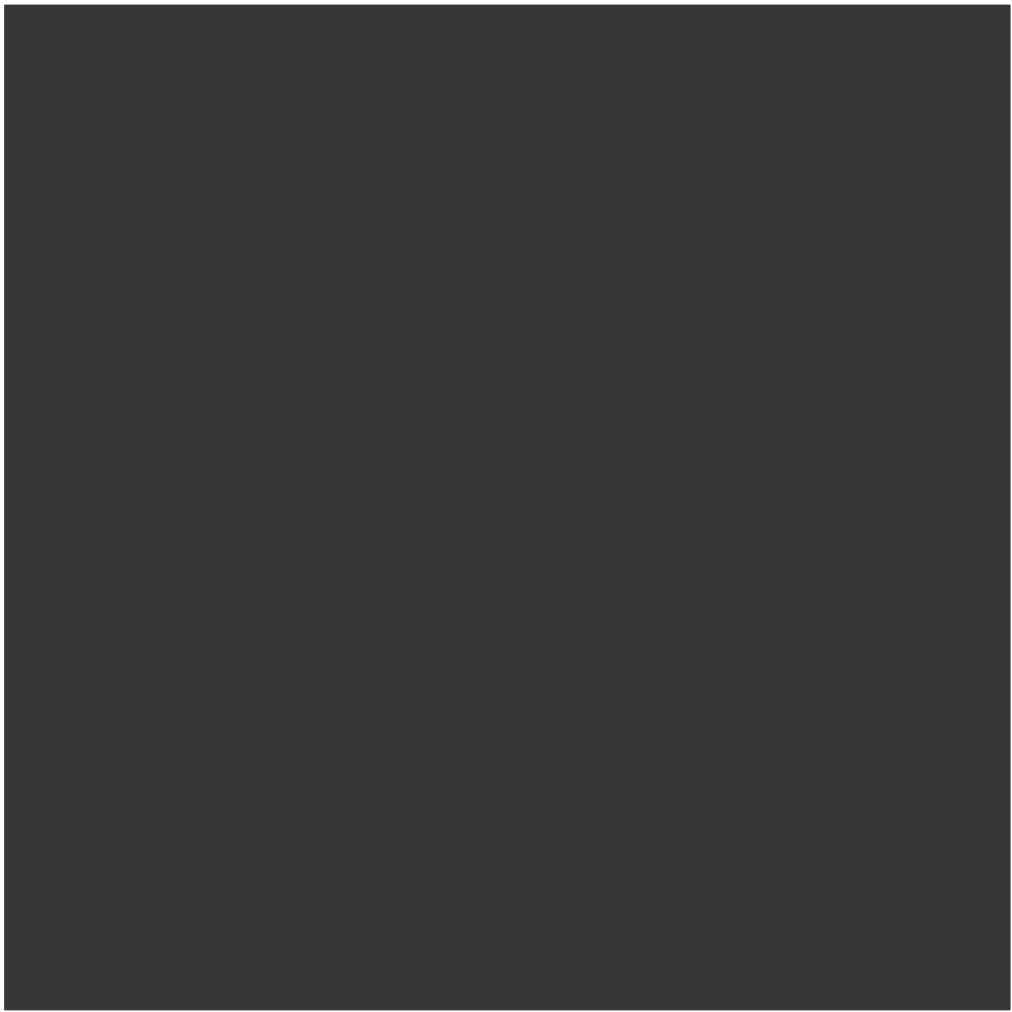

ADAMS MUSICAL INSTRUMENTS

Aziëstraat 17-19
NL-6014 DA Ittervoort
The Netherlands
T +31 (0)475 56 0710

export@adams.nl
www.adams-music.com



ADAMSPERCUSSION

#iplayadams

